

**PRODUCT DATA SHEET**  
May, 2009

**EURO EASY CLEAN TANK  
LINED TANK**

**GENERAL INFORMATION**

Vapor tight steel tanks manufactured in Europe with two sealed access hatches on top and one on the driver's side. Top-mounted pressure/vacuum relief valve. Smooth interior walls for easy cleaning. "V" shaped bottom improves drainage efficiency. RDW approved for transport throughout Europe.

**WEIGHTS AND MEASURES**

➤ <b>Capacity:</b>	..... 70.000 liters (70 m <sup>3</sup> ) 70.000 kilos
➤ <b>Height:</b>	..... 3.810 mm (service) 3.960 mm (transport)
➤ <b>Width:</b>	..... 2.505 mm (overall)
➤ <b>Length:</b>	..... 11.210 mm (overall)
➤ <b>Weight:</b>	..... 12.000 kg empty (approx)
➤ <b>Temperature Limits:</b>	..... Continuous - 50° C maximum Intermittent - 65° C maximum

**STRUCTURAL DESIGN**

➤ <b>Floor:</b>	..... 6 mm S235 carbon steel, "V" bottom sloping from each side to center.
➤ <b>Walls:</b>	..... 6 mm S235 carbon steel
➤ <b>Top Deck:</b>	..... 6 mm S235 carbon steel
➤ <b>Wall Frame:</b>	..... 150 mm x 80 mm x 6 mm c-channel, S355 carbon steel.
➤ <b>Floor Frame:</b>	..... Longitudinal beams with flat plate cross bracing between beams.
➤ <b>Top Frame:</b>	..... 150 mm x 80 mm x 6 mm c-channel, S355 carbon steel.

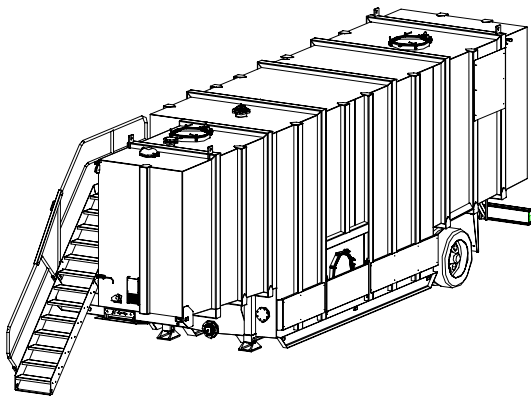

**FEATURES**

➤ <b>Valves:</b>	..... (1x) front 6" 150# ANSI drain and (1x) rear 4" 150# ANSI drain
➤ <b>Relief Valve:</b>	..... (1x) Cast aluminum thief hatch, NBR gasket, pressure setting 69 mBar, vacuum setting 1,7 mBar.
➤ <b>Misc. Pipe Connections:</b>	..... (1x) – front spare inlet/ outlet (blinded), 4" 150# ANSI flange ..... (1x) – top deck 4" 150# ANSI flange (blinded) for vapor recovery or top fill ..... (1x) – top deck 6" 150# ANSI flanged for level gauging device
➤ <b>Top Entry:</b>	..... (2x) – 600 mm hinged manways with restriction bars; NBR gasket
➤ <b>Side Entry:</b>	..... (1x) – 600 mm hinged manway on driver's side of tank; NBR gasket
➤ <b>Top Access:</b>	..... Front stairway to access landing
➤ <b>Guardrails:</b>	..... Along stairway and access landing
➤ <b>Tires:</b>	..... 275/70 R22,5 (doubles)
➤ <b>Suspension:</b>	..... Air suspension for easy on-site tank movement

**SURFACE DETAILS**

➤ <b>Exterior Coating:</b>	..... Weather and chemical resistant high gloss polyurethane finish (green)
➤ <b>Interior Coating:</b>	..... Chemical resistant polyamine epoxy lining. Call for specific chemical compatibility information.

**TESTS/CERTIFICATIONS**

➤ <b>Test Performed:</b>	..... • Approved for road transport throughout European Union. ..... • Quality control inspections Level 1, 2 & 3 on a scheduled basis. ..... • Hydrostatic water test after construction and major repairs. Tested to 1.3 specific gravity and 1 psi (69 mBar)
--------------------------	---

To the best of our knowledge the technical data contained herein are true and accurate at the date of issuance and are subject to change without prior notice. No guarantee of accuracy is given or implied because variations can and do exist. NO WARRANTY OR GUARANTEE OF ANY KIND IS MADE BY BAKERCORP, EITHER EXPRESS OR IMPLIED.